

Operation Manual

Safety Instruction

- Please read this manual carefully, also with related manual for the machinery before use the controller.
- For installing and operating the controller properly and safely, qualified engineers are required.
- Please stay away from arc welding equipment, in order to avoid electromagnetic interference and malfunction of the controller.
- Keep room temperature below 45°C and above 0°C
- Do not use in humidity below 30% or above 95% or dew and mist places.
- Please turn off the power and unplug the power cord, before install the control box and other components,
- To prevent interference or electric leakage accidents, please make the ground work; the power cord ground wire must be securely connected to earth by an effective way.
- All parts for the repair provided by the Company or approved before use.
- Please turn off the power and unplug the power cord before any maintenance action. There is dangerous high voltage control box, you must turn the power off after one minute before opening the control box.
- The symbol  in this manual means Safety Precautions, please pay attention to it and strictly follow it, to avoid any unnecessary damage.

1 Installation Instructions

1.1 Product specifications

Product Type	AHE70	Supply Voltage	AC 220 ±20%V
Power frequency	50Hz/60Hz	Maximum output power	550W

1.2 Interface plug connections

Connecting the plugs of pedaland machine head to the corresponding sockets at the back of controller, as Figure 1-2. Please check and confirm the plug is inserted firmly.

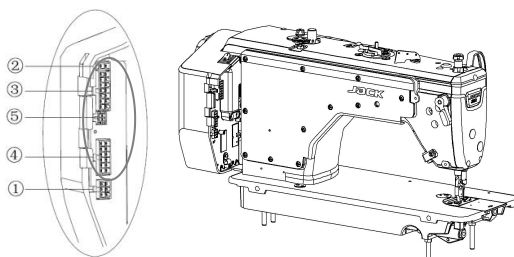



Fig.1-1 Controller Socket Diagram

- ① Pedal socket; ② Presser Foot lifter solenoid socket ; ③ Solenoid socket; ④Auxiliary Solenoid socket; ⑤Air suction tube socket

: If it is difficult to insert plug into socket, please check whether they are matching with each other, or the inserting direction or needle insertion direction is correct!

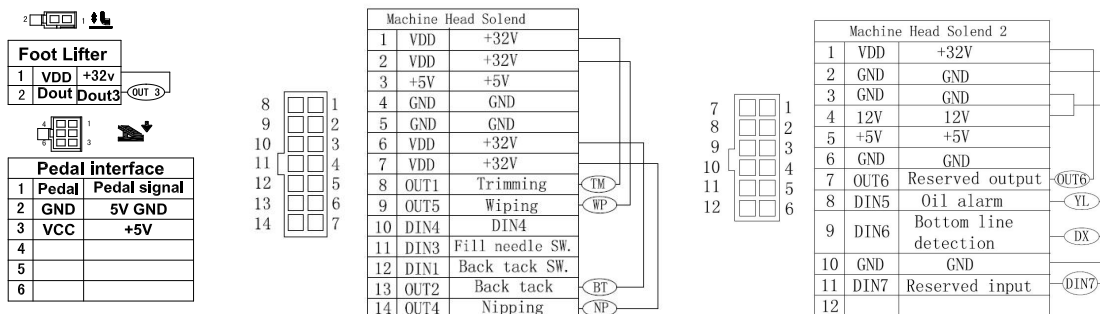



Fig.1-2 Controller Interface Definition

1.3 Wiring and Grounding

We must prepare the system grounding project, a qualified electrical engineer is requested for the construction. Product is energized and ready for use; you must ensure that the power outlet the AC input is securely grounded. The grounding wire is yellow and green lines, it must be connected to the grid and reliable security protection on the ground to ensure safe use, and prevent abnormal situation.

: All power lines, signal lines, ground lines, wiring not to be pressed into other objects or excessive distortion, to ensure safe use!

2 Operation Panel Instructions





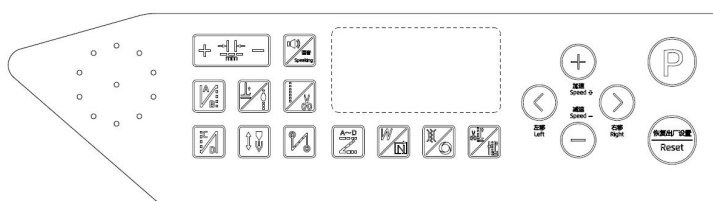















2.1 Operation Panel Display Instruction

According to the system working state, the LCD module of operation panel will display the current sewing mode, parameters, start / end back tacking, and presser foot, needle position, trimming, soft start sewing etc. Function mark of the operation panel is as follows:



2.2 Key Functions S/L mark Key Name Description

Key	Name	Description
	Parameter setting key	In the boot state, long press key to enter the parameter modes. After modify the parameters, press key to storage. Then long press key to exit this mode.
	Factory reset	Long press button for 5 seconds to restore the factory Settings.
	Stitch length adjustment key	1. Short press the "+" key, and the stitch length increases by 0.1mm each time. Long press the "+" key, and the stitch length continues to increase. 2. Short press the "-" key, and the stitch length decreases by 0.1mm each time. Long press the "-" key, and the stitch length continues to decrease.
	Power-on voice message and voice on/off key	Without error warning: 1. Short press key: The power-on voice is disabled. Short press again to enable the power-on voice. 2. Long press key: The voice function is disabled. Then, long press again to enable the voice function. With error warning: Short press key to broadcast the error code solution directly.
	Front reinforcing sewing key	Front reinforcing sewing selection key. Short press it once to switch between Front Reinforcing Sewing , Front Double-reinforcing Sewing , and Off. The corresponding LCD screen icon lights up. Select the corresponding key to set the stitch count in segments A and B. The range of stitch count 1~F corresponds to 1~15 stitches.
	Rear reinforcing sewing key	Rear reinforcing sewing selection key. Short press it once to switch between Rear Reinforcing Sewing , Rear Double-reinforcing Sewing , and Off. The corresponding LCD screen icon lights up. Select the corresponding key to set the stitch count in segments C and D. The range of stitch count 1~F corresponds to 1~15 stitches.
	Presser foot and small bird nest key	1. Short press key turn off the presser foot lifting function (At the same time, lifting the presser foot in the middle and lifting the presser foot after thread cutting are invalid), Press it again briefly, and the presser foot lifting function will be turned on. 2. Long press key ,Whether the loop in between is on for the small bird nest, and the corresponding LCD screen icon lights up.
	Free sewing and trimming key	1. Short press key to select free sewing mode. 2. Long press key, the thread trimming icon on the LCD screen lights up, and the thread trimming function is enabled. Long press key again to disable the thread trimming function.
	Stop position key	Short press key : Set the upper/lower needle position.
	Condensed sewing	Short press key : Condensed sewing selection key. Short press it once to switch between Rear Condensed Sewing, OFF, Front and Rear Condensed Sewing, and Front Condensed Sewing. The corresponding LCD screen icon lights up.
	Pattern sewing key	Short press to switch between Pattern Sewing Mode and Pattern Sewing Editing.





	W bar tacking /Multi-section constant-stitch	1, Short press  key, the icon  of LCD is lit, W seam marking function turns on. 2, Long press  key, the icon  of LCD is lit, the multi-section constant-stitch sewing function turns on.
	Tension/trigger key	1. Short press  key, the thread tension icon  on the LCD screen lights up, and the thread tension function is enabled. Short press it again to disable the thread tension function. 2. Short press  key, and the trigger function is enabled. Short press it again, and the trigger function is disabled (valid in multi-segment sewing mode).
	Presser foot key	1, Short press  key, the icon  of LCD is lit, the c sewing after the end of automatic trimming presser foot function turns on. 2, Long press  Key, the icon  of LCD is lit, the cycle sewing midway parking presser foot function turns on.
	Parameter increment key	1. In the Home interface, press  key to increase the speed by 50 rpm each time. 2. In the Parameter Setting, parameter value increment key.
	Parameter decrement key	1. In the Home interface, press  key to decrease the speed by 50rpm each time. 2. In the Parameter Setting, parameter value decrement key.
	The left selection key	Parameters selection toward to left key. (In constant-stitch sewing mode, long press this key, One-shot-sewing can be turned on or turned off.)
	The right selection key	Parameters selection toward to right key.

2.3 Operation panel auxiliary functions





2.3.1 User parameter adjustment

Normal boot, press  key to enter user parameter mode. Press the Left/Right key to move the cursor and the corresponding value digit flashes, then press the Plus/Minus key to modify the value of the digit. Press  key, the parameter number flashes, and save the parameter. Press  again to exit.

2.3.2 Needle stop position setting

In the power-on state, press  +  key to enter the monitor mode (display 024 parameter interface). At this time, turn the hand wheel to the upper needle position as required. The displayed value will change with the hand wheel position. Press  +  key to "set zero" to parameter value measured after 024 in the interface, confirm the upper needle position is OK, and calculate the lower needle position automatically at the same time.



2.3.3 Parameter save setting

In the monitoring interface state (press  +  key to enter), long press  to save the current parameters. In the power-on state, long press  key to restore the saved parameters.

2.3.4 Version number query

In the power-on state, press  +  key to enter the version display interface, and switch the display of program versions by pressing the Plus/Minus key, h**-*** represents the panel program version; A**-**-** represents the master control program version; V5-**** represents the voice version; V2-**** represents the recovery code.

2.3.5 Piece/stitch count setting

In the power-on state, press  +  key to enter piece/stitch count interface. Use the Left/Right key to switch between the piece/stitch count.

2.3.6 Step motor "Zero" calibration

In the power-on state, press  key to enter the user parameter mode. Adjust the parameter to item P81, use ordinary A4 paper, and measure at the speed 3500rpm. Adjust the parameter so that more than 10 stitches are performed by the needle in place. Press the P key to save; (if the stitch length is at forward feeds, the number decreases; if the stitch length is at reverse feeds, the number increases).

Note: Enter the P81 interface, and the stitch length will automatically become 0 to facilitate debugging. After exiting this interface, the stitch length will return to normal.

2.3.7 Stitch length adjustment setting

In the power-on state, press  key to enter the user parameter mode. Adjust the stitch length to 4.5mm and the parameter to P82 (stitch length compensation at forward feeds). Use ordinary A4 paper, measure at the speed 200 rmp, adjust the parameter to make the stitch length 4.0-4.5mm, and press P key to save; then enter P83 (stitch length compensation at reverse feeds), use ordinary A4 paper, sew a section forward, at the speed 200 rmp, press and hold the back-tacking switch. Adjust the parameters so that the forward feeds overlap more than 11 stitches, and press P key to save.

Note: Enter the P82 and P83 interfaces, and the speed will automatically become 200 rmp to facilitate debugging. After exiting this

interface, the speed will return to normal.

3 System parameters setting list

3.1 Parameter mode

- 1、 In the standby state ,press **P** key to enter the parameter modes.
- 2、 Press corresponding key **←** **→** and key **+** **-** to adjust the corresponding parameter.
- 3、 When the parameter values have increased and decreased, parameter interface flash. Short press **P** key to save the modified parameters .Long press **P** key to exit parameter interface, return to standby model.

NO.	Range	Default	Description
P 0 1	200~5000	3500	the maximum speed of free sewing (the global maximum speed)
P 0 2	0~100	0	Start sewing slight lift force adjusting
P 0 3	0/1	0	Needle stop position selection (0:up; 1: down)
P 0 4	200~3000	1800	Start back tacking speed
P 0 5	200~3000	1800	End back tacking speed
P 0 6	200~3000	1800	Continuous back sewing speed (W sewing)
P 0 7	5~720	300	After the motor runs to the target Angle, open the clip-on electromagnet
P 0 8	0~360	27	Clamp Angle compensation
P 0 9	0/1	0	Soft start switch (0:off; 1: on)
P 1 0	1~9	1	Slow-start stitch count
P 1 1	100~800	150	Slow-start sewing speed
P 1 2	0~2000	700	Slow-start sewing speed gradient increase
P 1 3	200~5000	4000	Manual backstitch maximum speed limit
P 1 4	100~800	200	Stitch compensation speed
P 1 5	0~2	0	Button stitch compensation mode: 0: Press the time control; 1: Compensate for half stitch; 2: Compensate for one stitch
P 1 8	1~120	15	Stitch balance for start back tacking No.1(Pull in compensation)
P 1 9	1~120	15	Stitch balance for start back tacking No.2(Release of compensation)
P 2 0	0~3	0	Front reinforcing working mode. 0: Press the pedal gently to start the initial backstitch automatically. 1: Controlled by the pedal, stop at will. 2: Controlled by [CT] time after the needle stops at the upper position 3: Controlled by [CT] time after the needle stops at the lower position
P 2 1	0~3	0	Rear reinforcing working mode. 0: Press the pedal gently to start the initial backstitch automatically. 1: Invalid 2: Controlled by [CT] time after the needle stops at the upper position 3: Controlled by [CT] time after the needle stops at the lower position
P 2 2	0~3	0	W reinforcing working mode. 0: Press the pedal gently to start the initial backstitch automatically. 1: Controlled by the pedal, stop at will. 2: Controlled by [CT] time after the needle stops at the upper position 3: Controlled by [CT] time after the needle stops at the lower position
P 2 3	0~4	4	Type of front/rear reinforcing mode (CD is similar to AB) 0: B->AB->ABAB->NONE; 1: B->NONE 2: B->AB->NONE 3: AB->NONE 4: AB->ABAB->NONE (Panel)
P 2 4	0~1024	80	Pedal trimming position
P 2 5	1~120	15	Stitch balance for end back tacking No.1
P 2 6	1~120	15	Stitch balance for end back tacking No.2
P 2 8	10~150	130	Thread tension start angle during front reinforcing and W sewing
P 2 9	160~359	250	Thread tension end angle during front reinforcing and W sewing
P 3 3	0~100	2	Tension force adjustment, the greater the parameter, the greater the force (When the parameter is 0, the clamping force is maximum)
P 3 4	0/1	0	Oil quantity detection switch (0 is on, 1 is off)
P 3 5	0~200	0	Bobbin thread detection switch (3 modes: digit 0-3)
P 3 6	200~2500	500	Bobbin thread detection mode (2 speed limit)
P 3 8	0/1	0	Bird's nest prevention quick switch: 0 is off, 1 is on

P 40	0~1024	300	Pedal presser foot lift position (greater than the previous parameter value in turn)
P 41	0~1024	500	Pedal back to center position (greater than the previous parameter value in turn)
P 42	0~1024	501	Pedal forward running position (greater than the previous parameter value in turn)
P 43	0~1024	650	Pedal low-speed running position (upper limit) (greater than the previous parameter value in turn)
P 44	0~1024	900	Pedal simulation maximum value (greater than the previous parameter value in turn)
P 47	200~360	360	After trimming anti pull (It realizes trimming is pulled back function)
P 49	100~500	250	Trimming speed
P 50	1~500	150	Presser foot lifting electromagnet full output time (ms)
P 51	1~100	9	Presser foot lifting electromagnet ON time per cycle (ms)
P 52	1~800	100	Presser foot release delay time (ms)
P 53	0/1	1	Presser foot lift switch: 0: not lifted 1: lifted
P 54	1~100	15	Presser foot lifting electromagnet Off time per cycle (ms)
P 56	0/1	1	Power on automatic upper needle position search: 0: no search 1: search
P 57	0~600	100	Presser foot lifting electromagnet protection time 100ms
P 60	200~5000	3000	Maximum fixed-length sewing speed (automatic speed test)
P 61	/	/	Motor initial angle detection quick parameter
P 62	0~4	0	Special mode: 0: normal Mode ; 1: simply sewing mode ; 2: motor initial angle measurement (Do not remove the belt); 3: Automatically setting the pulley ratio by the CPU. (Synchronizer is necessary and the belt not removed); 4: automatic test modle 1 (It has needle stop position of automatic test, running and stopping 5S)
P 63	0~10	0	Front condensed sewing switch (0: off, non-0: condensed stitch count)
P 64	0~10	2	Short thread switch (0: off, non-0: condensed stitch count)
P 65	200~2000	1000	Front condensed sewing speed
P 66	0/2	2	2: enable the safety switch function; 0: disable
P 67	0~359	10	Short thread angle compensation in quick, immediate trimming
P 71	0~50	2	Slow release presser foot level adjustment, the smaller the value, the faster the release; (overclock On time)
P 72	0~359	90	Broken needle prevention (0: off, non-0: press manual backstitch to find the suction angle, open normal 90)
P 73	0/1	0	Rear reinforcing function before thread trimming halfway of fixed stitch sewing (0: off, 1: on)
P 74	0/1	0	Operation mode selection after fixed length sewing is completed 0: rear reinforcing sewing 1: end sewing and standby (stitch compensation)
P 75	0/1	0	Thread trimming switch for each segment of multi-segment sewing (0: off, 1: on)
P 77	0/1	0	Manual backstitch function mode selection 0: Juki mode. Have action during sewing or stop halfway. 1: Brother mode. Have action only during sewing.
P 78	10~150	130	Tension start angle
P 79	160~359	320	Tension end angle
P 80	0/1	1	Whether to use step for stitch length adjustment
P 81	-999~999	45	Zero compensation
P 82	-250~250	0	Forward stitch length compensation
P 83	-250~250	0	Reverse stitch length compensation
P 84	200~3000	2000	Pattern sewing speed limit
P 85	0/1	0	Stitch length direction
P 86	0~50	8	Front short thread stitch length
P 87	0/1	0	Front short thread direction
P 88	0~50	5	Rear short thread stitch length
P 89	0/1	0	Rear short thread direction
P 90	0/1	0	Lock panel stitch length: 0: off; 1: on

P97	0/1/2	0	0 Boot voice and key voice 1 Boot voice only 2 Key voice only
P98	0~4	2	Voice volume adjustment (restore factory default without change)
P99	0/1/2	1	language selection 0: off, 1: Chinese, 2:English, default language 1 Chinese
PA6	1~100	1	Stitch count ratio setting
PA7	1~9999	1	Stitch count upper limit setting
PA8	0~6	0	Stitch counter mode option: 0: No counting;1: Count up according to stitch count, and recount automatically after the set value is count 2: Count down according to stitch count, and recount automatically after the set value is count 3: Count up according to stitch count, and motor stops automatically after the set value is count, restart by P button on the panel required. 4: Count down according to stitch count, and motor stops automatically after the set value is count, restart by P button on the panel required. 5: Count up according to the number of stitches. After counting up to the set value, an error is reported, and the motor does not stop. When the pedal is stepped on, the motor stops and the P key on the panel should be used to initiate the recount. 6: Count down according to the number of stitches. After counting up to the set value, an error is reported, and the motor does not stop. When the pedal is stepped backward, the motor stops and P key on the panel should be used to initiate the recount.
PA9	1~100	1	Trimming counter function ratio setting
PAA	1~9999	9999	Trimming count setting
PAB	0~4	0	Trimming counter mode option: 0: No counting;1: Count up according to Trimming count, and recount automatically after the set value is count 2: Count down according to Trimming count, and recount automatically after the set value is count 3: Count up according to Trimming count, and motor stops automatically after the set value is count, restart by P button on the panel required. 4: Count down according to Trimming count, and motor stops automatically after the set value is count, restart by P button on the panel required.

3.2 Monitor mode

No.	Description	No.	Description
010	stitch counter	025	The sampling voltage of pedal
011	Counter for sewing pieces	026	The ratio between motor and machine
012	The head of real speed	027	The total used time(hours) of motor
013	State of encoder	028	The sampling voltage of interaction
020	DC voltage	029	Software version
021	Machine speed	02A	Analog input 1
022	The phase current	02B	Analog input 2
023	Initial electrical angle	02C	Error counter
024	Machine angle	030-037	The history record of error codes

3.3 The warning message

Alarm code	Description	Corrective
ALA-2	Stitch counter alarm	The stitch counter reaches the limit. Press P key to cancel the alarm and reset the counter.
ALA-3	Trimming counter alarm	The trimming counter reaches the limit. Press P key to cancel the alarm and reset the counter.
POW OFF	Power is off alarm	Please wait for 30 seconds, then turn on the power switch
RPN UP	Safety switch alarm	Adjust the machine to the correct position.

3.4 Error mode

If the error code appears, please check the following items first: 1. Make sure the machine has been connected correctly; 2. Confirm that the control box match with the machine head. 3. Confirm factory reset is accurate

Error Code	Description	Solution
Err-01	Arm shaft motor hardware overcurrent	1. Turn off the system power, and turn it on again after 30 seconds. 2. Please enter P62 to check the initial angle of the arm shaft motor. 3. Check whether the arm shaft motor encoder and electronic control are damaged or in other poor conditions. If so, replace them in time. 4. If the system still does not work properly after troubleshooting and restart. Please contact your local service provider or call 4008876858.
Err-03	System undervoltage	Disconnect the power supply of the controller and check whether the input power supply voltage is lower than 176V. If so, please restart the controller after the voltage returns to normal. If the voltage returns to normal, it still does not work properly after the controller starts up. Please contact your local service provider or call 4008876858.
Err-04	Overvoltage during shutdown	Disconnect the controller power and check whether the input power voltage is higher than 264V. If so, please restart the controller after the voltage returns to normal. If the voltage returns to normal, it still does not work properly after the controller starts up. Please contact your local service provider or call 4008876858.
Err-05	Overvoltage during operation	

Err-06	Electromagnet circuit failure	<ol style="list-style-type: none"> 1. Turn off the system power, check whether the electromagnet connection is correct and whether there is any loose or damaged part. If so, replace it in time. 2. Unplug the 14-pin plug on the electric control to confirm whether the electric control is normal. If the electric control is normal, please check whether the electromagnetic circuits are damaged. 3. If the system still does not work after troubleshooting and restart. Please contact your local service provider or call 4008876858.
Err-07	Current detection circuit failure	Turn off the system power, and turn on the power again after 30 seconds to see whether it can work properly. Try a few times again. If the fault occurs frequently, please contact your local service provider or call 4008876858.
Err-08	Arm shaft motor stalled	<ol style="list-style-type: none"> 1. Please check whether there is any foreign object wrapped around the machine head, whether there is any thread residue stuck in the rotating shuttle, and whether the eccentric wheel of the machine is stuck. 2. Disconnect the power supply of the controller and check whether the input plug of the arm shaft motor power supply is detached, loose, or damaged. 3. Please enter P62 to check the initial angle of the arm shaft motor. 4. If the system still does not work properly after troubleshooting and restart. Please contact your local service provider or call 4008876858.
Err-10	Panel communication failure	<ol style="list-style-type: none"> 1. Please check whether the connection between the operation panel and the electric control is drops off, loose, or broken. 2. Please check whether the connection cable of the pedal speed controller is drops off, loose, or damaged. 3. If the system still does not work properly after troubleshooting and restart. Please contact your local service provider or call 4008876858.
Err-11	Head stop signal failure	<ol style="list-style-type: none"> 1. Check whether the connection between the arm shaft motor encoder and the controller is loose. 2. Replace the arm shaft motor encoder. 3. If the system still does not work properly after troubleshooting and restart. Please contact your local service provider or call 4008876858.
Err-12	Arm shaft motor initial angle detection failure	<ol style="list-style-type: none"> 1. Please enter P62 to check the initial angle of the arm shaft motor. 2. Please try 2-3 times again after power off. If it still fails. Please contact your local service provider or call 4008876858.
Err-13	Arm shaft motor zero position fault	<ol style="list-style-type: none"> 1. Turn off the power of the system, check whether the arm shaft motor encoder connector is loose, or drops off. Restore it to normal and restart the system. 2. Replace the arm shaft motor encoder. 3. If the system still does not work properly after troubleshooting and restart. Please contact your local service provider or call 4008876858.
Err-14	Master control eeprom components read/write failure	Turn off the system power, and then turn on the power again after 30 seconds. If the controller still does not work properly, please contact your local service provider or call 4008876858
Err-15	Arm shaft motor overspeed protection	
Err-16	Arm shaft motor reverse	
Err-17	Master control restart failure	
Err-18	Arm shaft motor overload	Check whether the arm shaft motor is stalled. If not, please contact your local service provider or call 4008876858.
Err-20	Alarm for oil shortage every 8 hours	Check whether the oil level of the machine is sufficient. If the problem is still not resolved after filling up the oil volume, please contact your local service provider or dial 4008876858.
Err-21	Arm shaft motor stalled	<ol style="list-style-type: none"> 1. Please check whether there is any foreign object wrapped around the machine head, whether there is any thread residue stuck in the rotating shuttle, and whether the eccentric wheel of the machine is stuck. 2. Disconnect the power supply of the controller and check whether the input plug of the arm shaft motor power supply is detached, loose, or damaged. 3. Please enter P62 to check the initial angle of the arm shaft motor. 4. If the system still does not work properly after troubleshooting and restart. Please contact your local service provider or call 4008876858.
Err-24	Bobbin detection alarm	Check whether the bobbin is sufficient. If the bobbin is sufficient but the error still exists, please contact your local service provider or dial 4008876858.
Err-26	Thread residue detection alarm	Restart after cleaning the yarn, if it still fails to work. Please contact your local service provider or call 4008876858.
Err-30	Password lock shutdown alarm	The machine has reached the set time. If further use is required, please contact your local service provider or call 4008876858.
Err-31	Backstitch step motor zero position fault	<ol style="list-style-type: none"> 1. Check whether the backstitch step motor, swing seat, and teeth are stuck. After the normal state is restored, restart the system. 2. Check whether the backstitch step encoder is damaged or in other poor conditions. If so, replace it in time. 3. If the system still does not work properly after troubleshooting and restart. Please contact your local service provider or call 4008876858
Err-32	Backstitch step motor hardware overcurrent	<ol style="list-style-type: none"> 1. Turn off the system power, and then turn on the power again after 30 seconds 2. Check whether the backstitch step motor, swing seat, and teeth are stuck. After returning to the normal state, restart the system. 3. If the system still does not work properly after troubleshooting and restart. Please contact your local service provider or call 4008876858
Err-33	Backstitch step motor current A detection circuit failure	Turn off the system power, and then turn on the power again after 30 seconds. If the controller still does not work properly, please contact your local service provider or call 4008876858.
Err-34	Backstitch step motor current B detection circuit failure	Turn off the system power, and then turn on the power again after 30 seconds. If the controller still does not work properly, please contact your local service provider or call 4008876858.
Err-35	Backstitch step motor Hall signal failure	<ol style="list-style-type: none"> 1. Check whether the backstitch step encoder and electronic control are damaged or in other poor conditions. If so, replace them in time. 2. Turn off the system power, and then turn on the power again after 30 seconds 3. If the system still cannot work properly after troubleshooting and restart. Please contact your local service provider or call 4008876858
Err-36	Backstitch step motor stalled	<ol style="list-style-type: none"> 1. Turn off the system power, and then turn on the power again after 30 seconds 2. Check whether the backstitch step motor, swing seat, and teeth are stuck. After returning to the normal state, restart the system. 3. Check whether the backstitch step encoder and electronic control are damaged or in other poor conditions. If so, replace them in time. 4. If the system still cannot work properly after troubleshooting and restart. Please contact your local service provider or call 4008876858

Digital AC Servo Controller Packing List



Attention:

Please check carefully whether the components listed on the packing list are all included. Please contact your supplier for compensation in case of missing parts.

Item	Type	Unit	Quantity
Controller		piece	1
Pedal assembly(including bracket)		set	1
Operation Panel		piece	1
Fetlock pitman		piece	1
Wood screw	ST4.8*22.9	piece	3
User manual			1

Warranty Card

Please fulfill this Warranty Card and fax it to us, purpose for getting a customer servicenumber, only through it the products maintenance and other technical service could bewarranted. In case of more than one set of product are once purchased, only one warranty card needed but all product bar code should be enclosed.

Model : _____ **Warranty Period :** 2 years **Product bar code :** _____

User Name : _____ **Address :** _____ **Purchasing date :** _____

Notice :

1. This card is important evidence with which customer can obtain maintenance service and technology support, please keep it well.
2. The warranty period is calculated since the product is sold,if the proof is not provided,corresponding time will adds one month from production date.
3. For those errors which happen in normal condition and without man-made misplay during theperiod, in terms of warranty content, with original warranty card and purchasing certification.We will provide free repair service and technology support till the product can work normally.
4. Repair service and technology support under following conditions will charge during warranty period.
 - a. Valid warranty card and purchase certification can not be provided.
 - b. Contents of the warranty card are not complete or be altered.
 - c. The fault or damage is caused by unavoidable force.
 - d. The fault or damage is caused during transportation or uploading.
 - e. The fault or damage is caused by unauthorized removing, repairing and/or refitting.
 - f. The fault or damage is caused by irrational operation, which does not obey the regulated methods in the manual.

Toll free Hotline: 800-820-7693/400-820-7693 www.powermaxtech.com

INSPECTION CERTIFICATE

NAME Digital AC Servo System DATE See bar code _____

MODEL See bar code _____ INSPECTION _____